

# ODBORNÝ TECHNICKÝ SEMINÁŘ

ISCAR ČR s.r.o. – MISAN s.r.o. 10. a 11. června 2015

Ukázka obrábění nástroji ISCAR  
na stroji OKUMA LU3000EX

Obráběný materiál: ČSN 12050

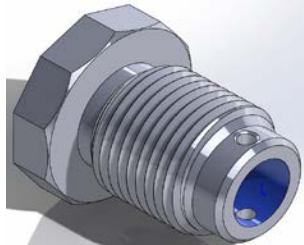

## 1) Soustružit čelo a povrch nahrubo

<i>Operace:</i>	soustružení	<i>Stroj:</i>	OKUMA LU3000EX			
<i>Materiál:</i>	12050	<i>Chlazení:</i>				
<i>Nástroj:</i>	MWLNL 2020K-06W	<i>VBD:</i>	WNMG 06T308-M3P	<i>Jakost:</i>	IC8150	
<i>Rezná rychlost:</i>	250 m/min	<i>Otáčky:</i>		<i>Ap:</i>	2,5 mm	
<i>Posuv / ot:</i>	0,25 mm/ot	<i>Posuv:</i>				

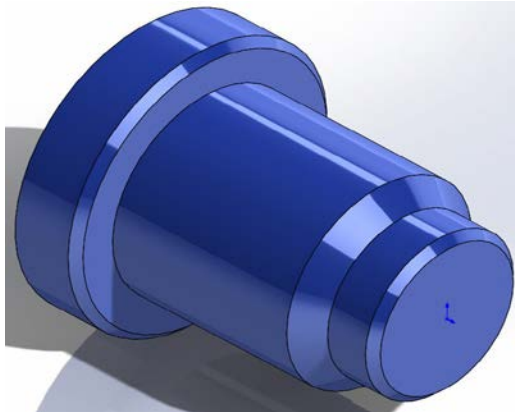

## 2) Soustružit čelo a povrch načisto

<i>Operace:</i>	soustružení	<i>Stroj:</i>	OKUMA LU3000EX			
<i>Materiál:</i>	12050	<i>Chlazení:</i>				
<i>Nástroj:</i>	SDJCL 2020K-11	<i>VBD:</i>	DCMT 11T304-F3P	<i>Jakost:</i>	IC8150	
<i>Rezná rychlost:</i>	280 m/min	<i>Otáčky:</i>		<i>Ap:</i>	0,5 mm	
<i>Posuv / ot:</i>	0,17 mm/ot	<i>Posuv:</i>				

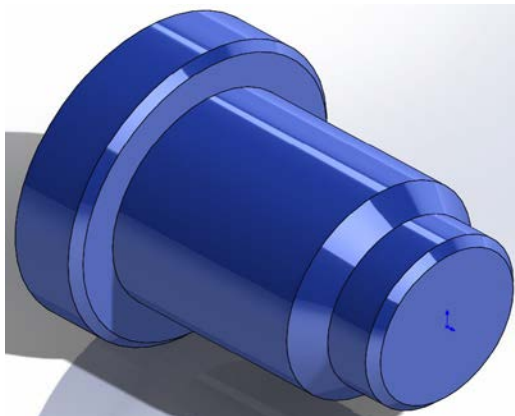

### 3) Soustružit zápich za zápichem

Operace:	zapichování	Stroj:	OKUMA LU3000EX			
Materiál:	12050	Chlazení:				
Nástroj:	PCHL 20-D40-3-IQ	VBD:	PENTA D40N300C020	Jakost:	IC808	
Řezná rychlost:	150 m/min	Otáčky:		Ap:	2,5 mm	
Posuv / ot:	0,15 mm/ot	Posuv:		W:	3 mm	

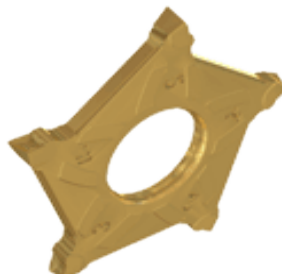
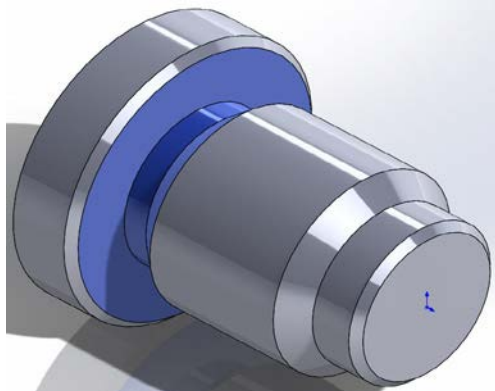

### 4) Soustružit závit M25x2

Operace:	soustružení závitu	Stroj:	OKUMA LU3000EX			
Materiál:	12050	Chlazení:				
Nástroj:	PCHL 20-24	VBD:	PENTA 24-2.0-ISO	Jakost:	IC908	
Řezná rychlost:	150 m/min	Otáčky:		průchody	15	
Posuv / ot:	2 mm/ot	Posuv:				

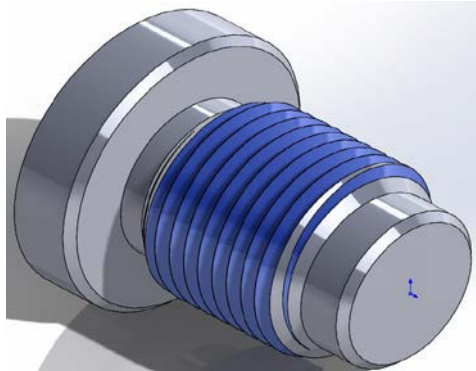

### 5) Frézovat 10tihran

Operace:	frézování	Stroj:	OKUMA LU3000EX			
Materiál:	12050	Chlazení:				
Nástroj:	EC-E4L 12-26/38C12CF83 90	VBD:		Jakost:	IC 900	
Ø nástroje	12 mm	Počet zubů	4	vyložení:	42 mm	
Řezná rychlost:	120 m/min	Otáčky:	3183 ot/min	Ap:	8 mm	
Posuv / zub:	0,12 mm/z	Posuv:	1528 mm/min	Ae:	1 mm	

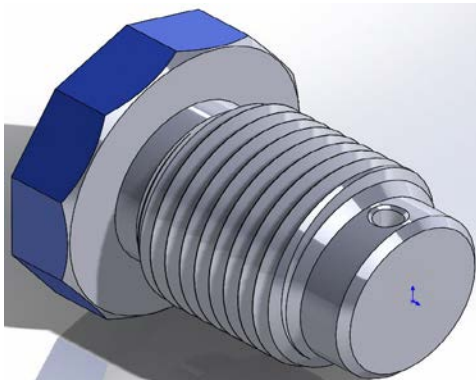

## 6) Vrtat otvor pr. 3,3mm

<i>Operace:</i>	vrtání	<i>Stroj:</i>	OKUMA LU3000EX		
<i>Materiál:</i>	12050	<i>Chlazení:</i>	emulze		
<i>Ø nástroje</i>	3,3 mm	<i>Počet zubů</i>	1		
<i>Nástroj:</i>	SCDT 033-011-060-M4	<i>VBD:</i>		<i>Jakost:</i>	IC 908
<i>Řezná rychlost:</i>	50 m/min	<i>Otáčky:</i>	4823 ot/min	<i>hl:</i>	12 mm
<i>Posuv / ot:</i>	0,1 mm/ot	<i>Posuv:</i>	482 mm/min		

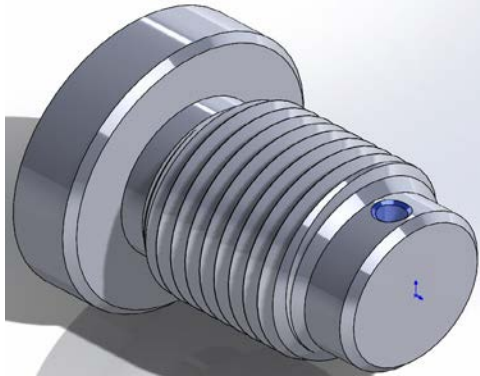

## 7) Vrtat otvor pr. 13mm

<i>Operace:</i>	vrtání	<i>Stroj:</i>	OKUMA LU3000EX		
<i>Materiál:</i>	12050	<i>Chlazení:</i>	emulze		
<i>Ø nástroje</i>	13 mm	<i>Počet zubů</i>	1		
<i>Nástroj:</i>	DCN 130-104-16A-8D	<i>VBD:</i>	HCP 130-IQ	<i>Jakost:</i>	IC 908
<i>Řezná rychlost:</i>	110 m/min	<i>Otáčky:</i>	2917 ot/min	<i>hl:</i>	12 mm
<i>Posuv / ot:</i>	0,2 mm/ot	<i>Posuv:</i>	584 mm/min		

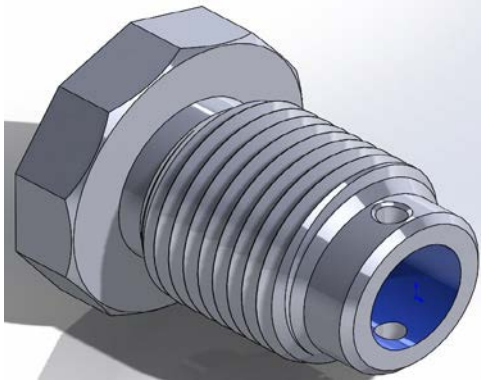

## 8) Upíchnout díl

<i>Operace:</i>	Upichování	<i>Stroj:</i>	OKUMA LU3000EX		
<i>Materiál:</i>	12050	<i>Chlazení:</i>			
<i>Nástroj:</i>	PCHL 20-D40-3-IQ	<i>VBD:</i>	PENTA D40N300C020	<i>Jakost:</i>	IC808
<i>Řezná rychlost:</i>	180 m/min	<i>Otáčky:</i>		<i>Ap:</i>	20 mm
<i>Posuv / ot:</i>	0,2mm/ot	<i>Posuv:</i>		<i>W:</i>	3 mm

